

Step 1
HOLE SIZE

The hole needed to lay the MufieDrain channel must allow not only for the size of the channel and the drain piping but also for adequate space for the base H and the side concrete props S. The dimensions to be followed are shown in the summary table. In this step make sure the underlying layer is suitable to the load it is expected to support.

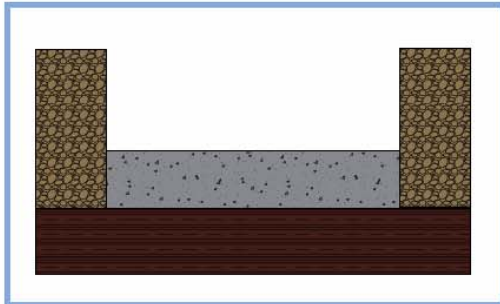

Step 2

CONCRETE BASE

Cast the concrete base H up to the height specified, allowing for any inclination in the drainage line. If needed, equip the base with stretches of electrowelded mesh or steel rods.

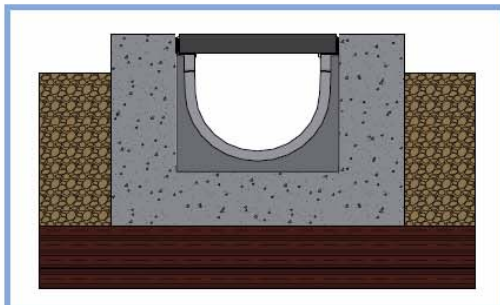

Step 3

CHANNEL ARRANGEMENT

Lay the channels starting from the flow outlet. Allow for the drains required and build the side prop S up to the maximum height allowed by the final coating. Shape it according to the needs based on the drawing. Introduce and fix the grating required beforehand in order to prevent any deformation of the channel due to the thrust of concrete and to speed up installation. Protect the gratings with a PVC film so that no final cleaning must be carried out to remove any concrete residues.

NEW FEATURE:

The channels can be installed with preassembled gratings.

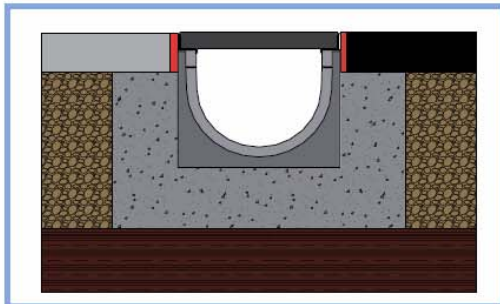

Step 4

FINAL COATING

When applying the final coating, make sure its upper profile reaches up to minimum 3/5 mm above the grating's flow plane (see details on the following page). Remove the protection film.

Case 1
Asphalt
(B125-C250)

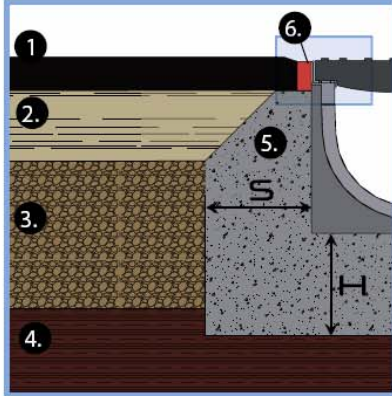

1. Sheet asphalt
2. Lower layer (binder)
3. Bearing layer
4. Subfloor
5. Concrete reinforcement layer
6. Bitumen joint

Case 3
Concrete flooring
(from B125 to F900)

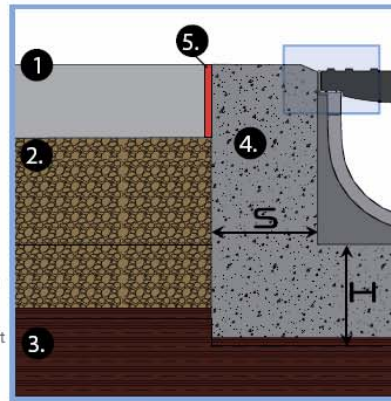

1. Concrete flooring
2. Bearing layer
3. Subfloor
4. Concrete reinforcement layer
5. Bitumen joint

Case 2
Asphalt
(D400-E600-F900)

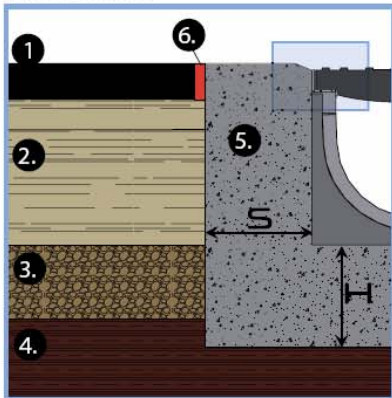

1. Sheet asphalt
2. Lower layer (binder)
3. Bearing layer
4. Subfloor
5. Concrete reinforcement layer
6. Bitumen joint

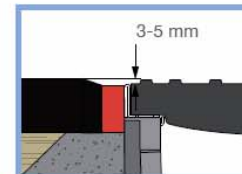

This Sheet is only aimed to give advice on the installation of channels mod. MufleDrain. In any case, always:

- check the carrying capacity characteristics of the underlying layer
- use concrete and stone aggregate having the characteristics recommended
- comply with the height of the installation surface and the thickness of the prop as specified according to the load classes.

SUMMARY TABLE

Load class (EN 1433)		B 125	C 250	D 400	E 600	F 900
Applicable load (EN 1433)	kN	125	250	400	600	900
Minimum height H of concrete laying bed	mm	100	150	200	200	250
Minimum thickness S of the concrete flanking	mm	100	150	200	200	250
Concrete compression strength class (EN 206-1)		C 25/30	C 25/30	C 25/30**	C 30/37	C 35/45
Concrete compression strength class* (EN 206-1)		C 30/37 XF4	C 30/37 XF4	C 30/37 XF4	C 35/45 XF4	C 40/50 XF4

* If concrete can be affected by frost and thaw cycles.

If installation is in road crossings subject to heavy traffic (especially trucks), Class C30/37 concrete should be used.
N.B. We recommend using Class S4 concrete (EN 206-1) and stone aggregate with maximum diameter 8 mm.

Contech Accessories Ltd, Tullow, Co. Carlow. **Tel:** +353 (0)59 9151350

Email: sales@contech-accessories.ie

Web: www.contech-accessories.ie